

**Raise trailer with jockey wheel/stand to just above tow ball height and reverse vehicle to trailer (do not drag trailer to vehicle.)**

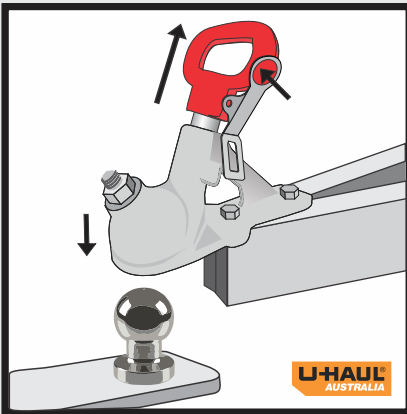

**Press coupling handle trigger inwards and pull up handle to enable coupling to be attached or unattached from tow ball.**

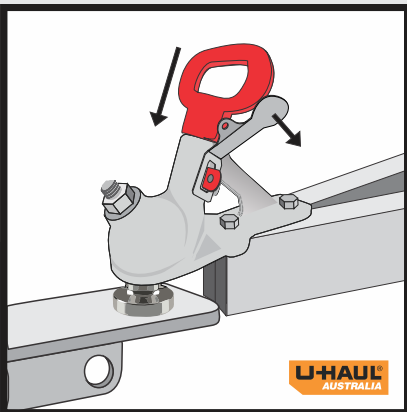

**Push handle down and release coupling handle trigger once positioned and lower coupling on to a correctly rated 50mm tow ball. Coupling is now in the locked down position ready for towing.**

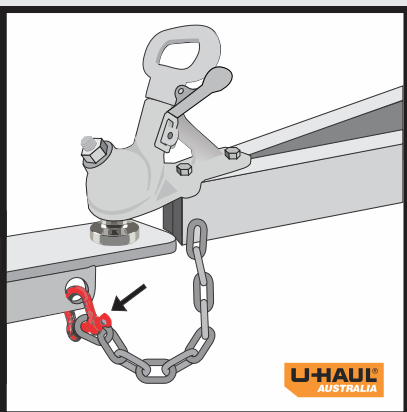

**Connect the safety chain/s with D-Shackle/s to the towing vehicle. Cross over chains (if more than one chain) and do not allow to drag on the road.**



Ensure electrical lead is attached to trailer and vehicle using the correct plug. Check electrical lead is secure to avoid dragging on the road and all lights are working before towing.



## TRAILER ATTACHING GUIDE (3500KG ATM)

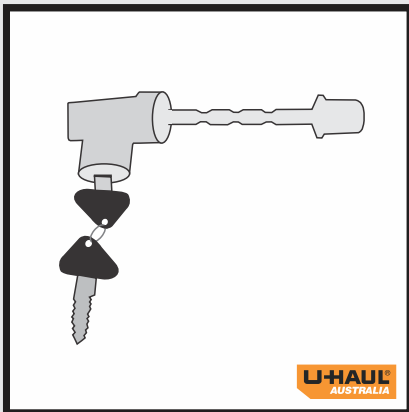

Remove coupling lock and return lock & key to hire location attendant.

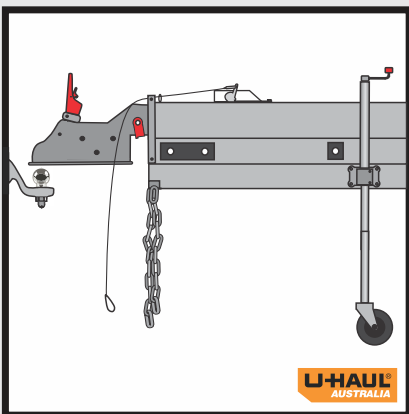

Raise trailer/caravan with jockey wheel /stand to just above tow ball height and reverse vehicle to trailer (do not drag trailer to vehicle). Recommended height of tow ball is between 420mm-460mm).

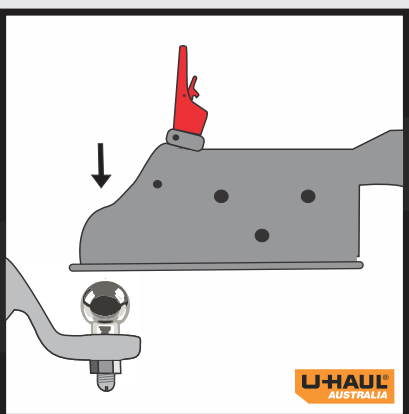

Lift lock lever to unlocked position (vertical) and lower coupling on to a correctly rated 50mm tow ball until locking handle releases to a horizontal position.

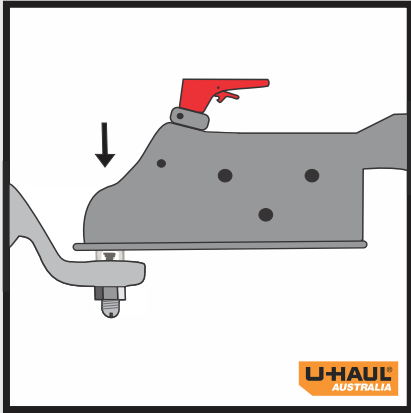

Coupling is now in the locked down position (lock lever horizontal) and ready for towing.

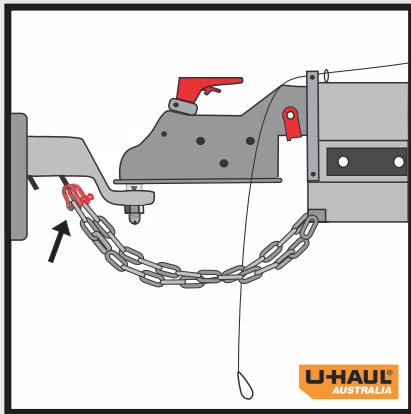

Connect the safety chain/s with D-Shackle/s to the towing vehicle. Cross over chains (if more than one chain) and do not allow to drag on the road.

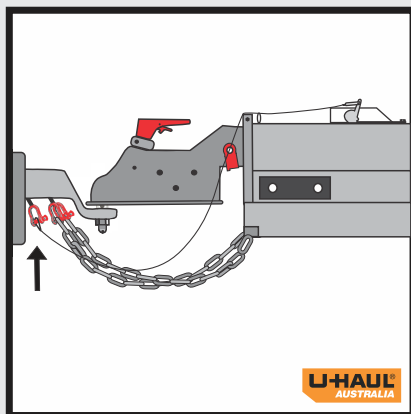

Attach breakaway cable to vehicle separately from the safety chains (do not attach cable to safety chain or D Shackle).



Check electrical lead is secure to avoid dragging on the road and all lights are working before towing.

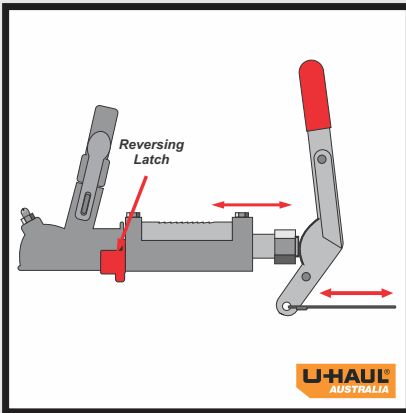

The trailers brakes are operational when the reverse latch is in the **OPEN** position.

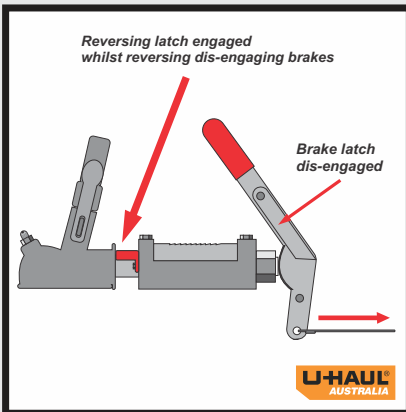

When reversing the trailer, the latch must be in the **CLOSED** position to disengage the braking system.

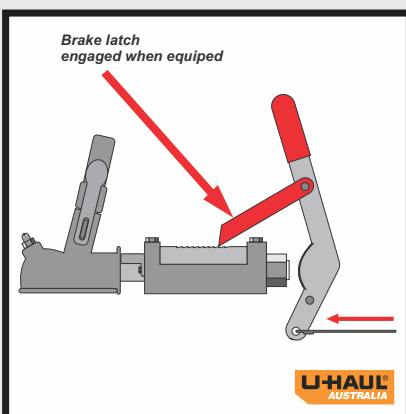

The handbrake is engaged when the handle is pulled back fully and ratchet lever is down in locking groves (if lever is included). **NB: wheel chocks MUST always be used also.**

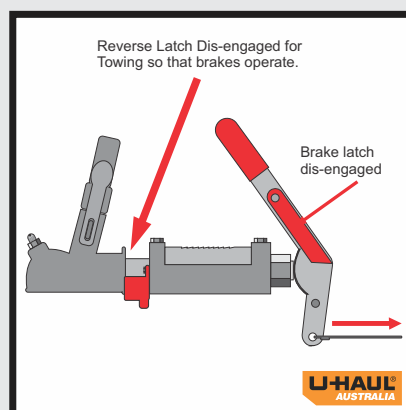

To release handbrake pull handle back and lift ratchet lever (if lever is included) away from locking groves. **NB: the ratchet lever must be in this position whilst towing trailer with vehicle.**



## SAFE OPERATION OF BRAKES (3500KG ATM)

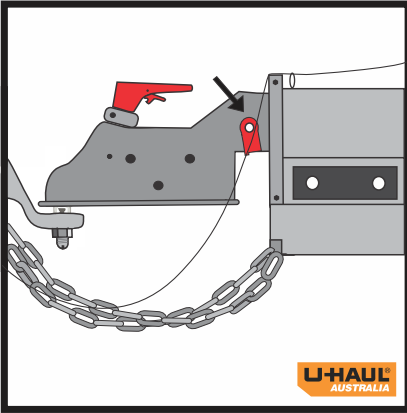

The trailer/caravan brakes are operational when the reverse latch is in the **OPEN** position.

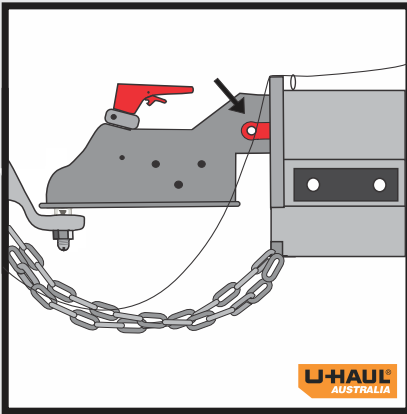

When reversing the trailer/caravan, the latch must be in the **CLOSED** position to disengage the braking system.



## SAFE OPERATION OF JOCKEY WHEEL/STAND

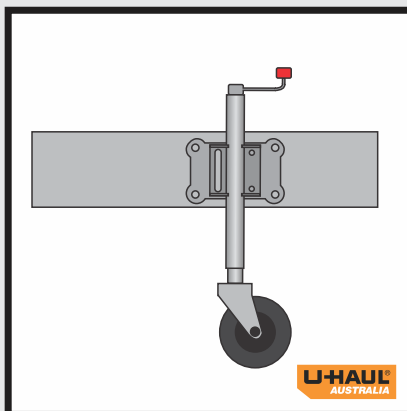

Jockey Wheel/Stand only to be in the vertical position when the trailer is being attached or unattached from the towing vehicle, or in a parked position.

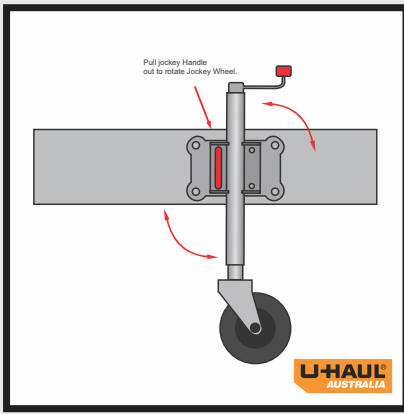

**Pull out handle and rotate to enable Jockey Wheel/Stand to be put in the horizontal position (ensure no load/weight is on the stand).**

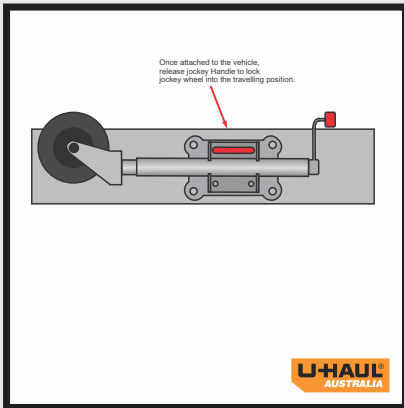

**Jockey Wheel/Stand MUST be in the horizontal position with both wheel and handle placed upwards before you commence towing.**



## TOW BALL SIZE



**Use only a correctly rated 50mm tow ball.**